

A photograph of several icebergs floating in dark teal water. The icebergs are white and blue, with some showing signs of melting and cracking. The water is a deep, dark teal color. The overall scene is serene and somewhat somber, suggesting a theme of climate change or environmental impact.

WHITEPAPER

Weighing the Costs:

Understanding the environmental,
financial and safety costs of
VRF Systems

jaga CLIMATE DESIGNERS

WHITEPAPER

Weighing the Costs:

Understanding the environmental,
financial and safety costs of
VRF Systems

INTRODUCTION

It's a vicious circle: Temperatures rise due to climate change; more air conditioning is required to cool buildings as temperatures rise; refrigerants used in air conditioning contribute to climate change.

Where does it end?

To make matters worse, the number of cooling devices globally is estimated to almost triple [↗](#) by 2050, from 3.6 billion units to 9.5 billion.

When considering various actions we can collectively take to reduce our environmental impact, transitioning to all electric cars and eliminating deforestation will help, but eliminating high-global-warming potential refrigerants from commercial and residential buildings is estimated to be one of the single largest actions we can take to reduce global warming. According to the BBC [↗](#), the cooling industry accounts for approximately 10 percent of global CO₂ emissions—three times the amount produced by the aviation and shipping industries combined.

Refrigerants are everywhere. From our air conditioning units to residential clothes dryers to soda dispenser machines, they exist in places you'd never imagine. Unfortunately, many refrigerants are classified as greenhouse gasses that actively contribute to ozone depletion.

In the HVAC industry, refrigerants such as R410A and R32A are commonly used in Variable Refrigerant Flow (VRF) systems. Introduced to North America in the early 2000s, VRF systems have become increasingly popular because of their claims of low cost and high efficiency. Developed in Japan, it is a proprietary system that connects centralized condensers with multiple evaporators using refrigerant that flows throughout copper piping.

Within North America, the number of VRF manufacturers continues to grow along with the claims associated with the system. However, before taking the plunge into VRF and refrigerants, it's important to look beyond initial price and manufacturer's claims and instead, look at the full cost of these systems.

In this white paper, we will address some of the most common misconceptions associated with VRF Systems and refrigerants, including damage to the environment, true economic cost and related safety concerns. Then we'll present reasons to consider hydronic alternatives.

A History of Refrigerants

Many people think that because VRF Systems don't directly use fossil fuels known to contribute to global warming, they are better for the environment. Although they do operate on electricity, studies have shown that the refrigerants used in VRF Systems are worse for the environment than alternatives.

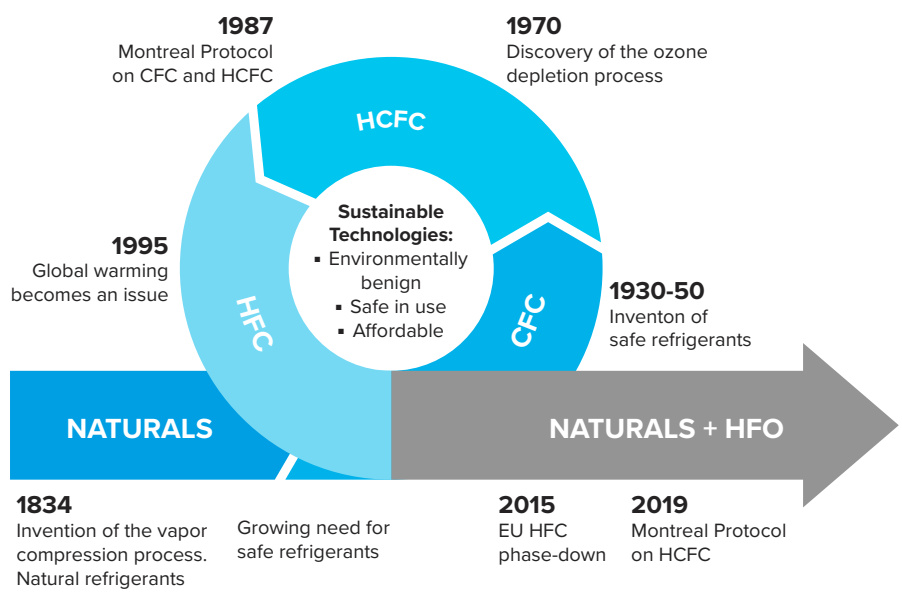

When first invented, most refrigerants were chloroflourocarbons (CFCs), but when scientists found they contributed to the depletion of the ozone layer, there was a worldwide agreement to phase them out—the 1987 Montreal Protocol.

Subsequently, this ban resulted in the development of two different groups of refrigerants, known as hydroflourocarbons (HFCs) and hydrochloroflourocarbons (HCFCs).



Cost #1
The Environmental
Cost of VRF Systems

Environmental Costs

According to the [BBC](#), “These refrigerants break down ozone molecules far less, but are extremely potent greenhouse gasses. Their capacity to warm the atmosphere—measured as global warming potential—is thousands of times greater than carbon dioxide, with some being up to 13,850 times more potent.”

In fact, 2 pounds of R410A has the same greenhouse effect as running your gas-powered car for six months.

Their danger lies in their ability to trap heat inside the atmosphere, rather than permitting the heat to be released back into space.

As noted, coolant is used in many different applications; however, refrigeration and air conditioning are the two largest sources of coolant emissions. Some HFCs can remain in the atmosphere for up to 29 years, which is why efforts are underway to radically transform the way we cool residential and commercial buildings.

To combat the impact of coolants, more than 150 countries joined together to sign the

Kigali Amendment in 2016, which resulted in the eventual phaseout of R410a beginning in January 2023. R410a replaced the R-22 refrigerant, which the U.S. EPA banned on Jan. 1, 2010.

Used within a system, emissions from refrigerants are contained. However, [Project Drawdown](#), a non-profit organization that studies climate solutions, reports that 90 percent of refrigerant leaks occur at the end of the equipment’s life. When leaked into a building or the environment, these chemicals can create major issues that go beyond environmental risks, including health and safety problems—more on that later.

The banning of refrigerants impacts the longevity of existing VRF systems and contributes to the scarcity of repair parts—an action that will increase as we attempt to curb the impact of human activity on the climate. For example, after 2025 when the R410a phase out is complete and R410a is officially banned, the increasingly popular “split system” (a VRF system designed for R410a) will need to be replaced as repair parts become scarce.



Cost #2
The Energy Cost
of VRF Systems

Energy Costs

When it comes to efficiency, VRF manufacturers commonly claim that their systems perform better than any competing heating and cooling systems; however, [independent research](#) suggests that these claims are baseless.

According to an article in [PM Engineer](#), a study conducted in a building retrofit at the ASHRAE headquarter building in Atlanta compared a hydronic system against a VRF System. Engineers installed a hydronic system with a geothermal ground source heat pump with constant-speed compressors on the second floor of the building and a VRF system with variable-speed compressors on the ground floor.

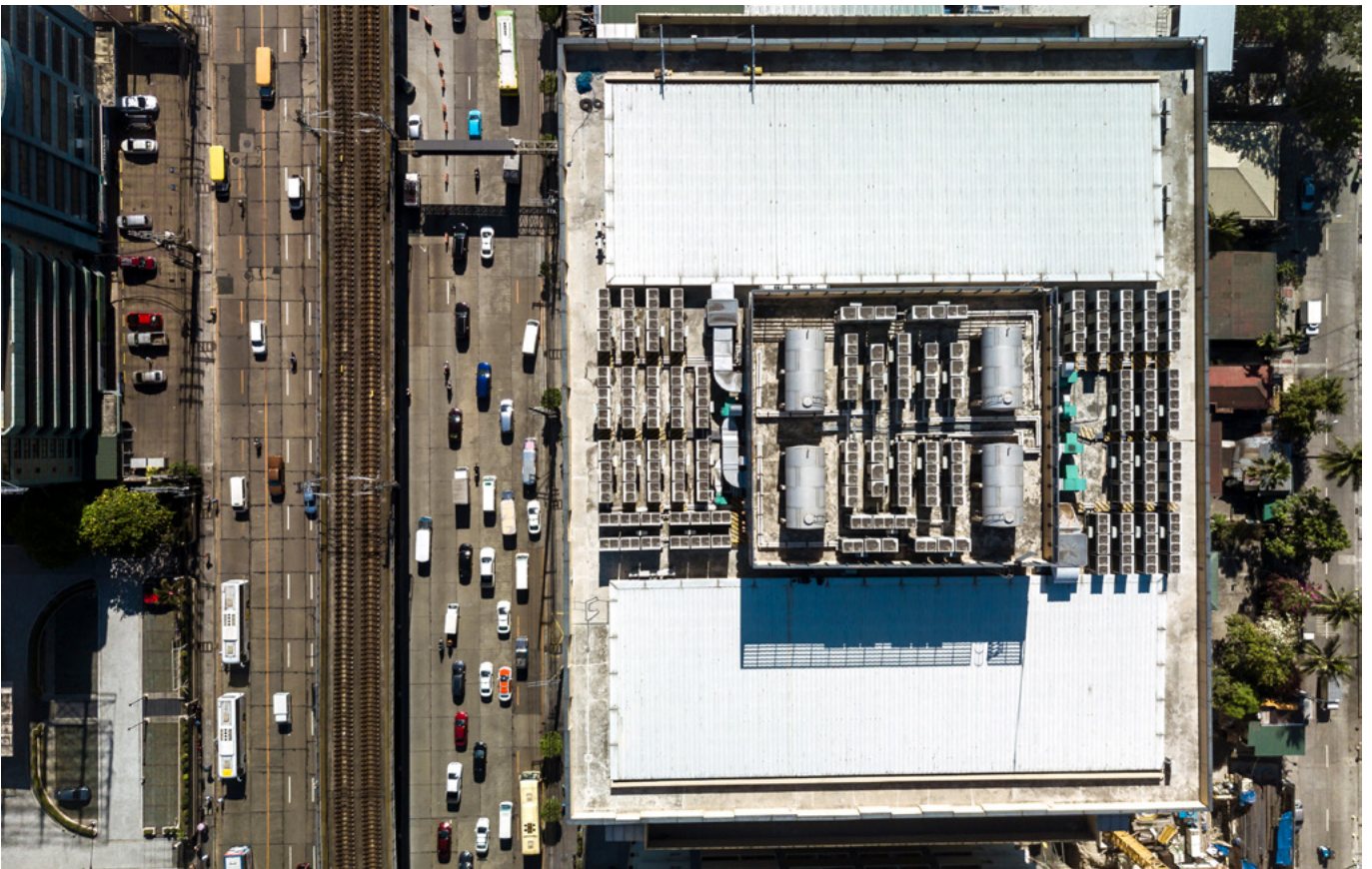



According to author Greg Cunniff, P.E.,

“ Both systems use no backup heat and rely solely on the electric energy to the compressors to both heat and cool the building, affording an apples-to-apples comparison.”

In the two years the study was conducted, data revealed that the VRF system consumed 60 to 85 percent more energy than the geothermal heat pump system.

“Proponents of VRF Systems claim the systems do not need backup heat, even in heating climates,” he said. “However, the systems achieve this performance by speeding up the compressor, up to double the speed, to produce higher heating capacities at lower ambient temperatures. This occurs at the expense of efficiency. If a variable-speed compressor has a higher efficiency at reduced speed it will have a lower efficiency at increased speed.”

Specific energy efficiency advantages marketed by VRF manufacturers include zoning capabilities, heat recovery potential and reduced energy inputs—all features achieved with a hydronic system.

A close-up photograph of a VRF system's copper piping. The image shows several vertical copper pipes and horizontal fittings connected to a metal panel. The copper has a warm, reddish-brown hue with some darker, oxidized areas. The background is a textured, metallic surface, possibly aluminum or steel, with some circular openings. The lighting is dramatic, highlighting the textures and colors of the metal.

Cost #3
The Financial Cost
of VRF Systems

Financial Costs

Frequently touted as a more economical alternative, VRF systems have a much greater cost over the entire lifetime of the product. A number of hidden costs greatly increase the cost of the system over its lifetime, which include additional material, labor and proprietary controls.

1. Material Costs:

VRF Systems require copper piping that must meet a specific grade because of the high fluid pressures and the temperature of the R-410A fluid. ASTM B280 rated copper costs \$346.12 for 50 feet of 7/8-inch tubing whereas 60 feet of 2 1/2-inch Schedule 40 carbon steel piping (typically used for hydronic heating applications) cost only \$22.80 for the same amount.

2. Labor Costs:

Because of the potential hazards associated with VRF systems, installers must be qualified to work with refrigerants as well as relevant ASHRAE codes. Ultimately, installing a VRF system means that not just any HVAC mechanic can provide maintenance on the system—it'll require a specific person to assist.

3. Proprietary Controls:

Where many hydronic systems can work with interchangeable components such as thermostats, VRF systems specify strictly what features can be used. If in a few years one component fails, a building owner might have to change the entire system. These controls can be higher in cost to replace.

4. Energy Consumption:

A study by the [Hydronic Industry Alliance](#) compared VRF systems with a similarly sized hydronic system, installed in the same building, and found that “On an annualized basis, the VRF system had an energy consumption 57% higher in 2010 than the hydronic system, 84% higher in 2011 and 61% higher in 2012.”

5. Shorter Lifespan:

VRF systems could need replacing as soon as 10 or 15 years after installation, compared to hydronic systems, which are known to last 20 to 25 years. The compressor in a VRF system is forced to work harder during heating cycles, reducing the life of the compressor. As long as water, the main ingredient used in a hydronic system, is available, heating and cooling systems that use it also will be available.

A photograph of a male technician wearing a white hard hat, safety glasses, and a dark long-sleeved shirt. He is working on an outdoor VRF system unit. The unit is a large, light-colored metal cabinet with a wire mesh door. The technician is holding a small, light-colored plastic component, possibly a filter or a part of the control panel. In the foreground, there is a smaller, light-colored electrical control box with a label that reads "AC-3". The background shows a clear blue sky and a building structure.

Cost #4
The Safety Risks
of VRF Systems

Safety Risks

Safety is one of the primary concerns with a VRF system, as coolant can replace oxygen which poses inhalation risks to anyone in the building. Occupants are subject to difficulty breathing or suffocation, particularly in environments with little to no ventilation.

R-410a is heavier than air, causing the gas to sink and accumulate in the lower portions of the room near the floor. In addition, some refrigerants are flammable, so leaks may also present the risk of combustion which could impact building individuals beyond the immediate area of the leak.

A writer for [HPAC Engineering](#) ¹ recounts a story where young, inexperienced technicians became unconscious while working on a large refrigerant system.

In 2017, the U.S. Department of Defense directed that [VRF systems could no longer be used](#) ² in U.S. Air Force facilities and discouraged in Army buildings. Two of the three reasons cited for the decision included:

1. Concern over refrigerant concentration, as a typically sized VRF system contains enough refrigerant to potentially asphyxiate occupants in the event of a refrigerant leak,
2. Difficulty in locating refrigerant leaks due to long refrigerant lines that are common with VRF systems.



To reduce the impact of a special leak, ASHRAE has developed specific standards ([ASHRAE Standard 15: Safety Standard for Refrigeration Systems and Designation and Classification of Refrigerants](#)) [↗](#) around the installation and maintenance of VRF Systems, including the amount of fluid that can be used in a single refrigerant circuit.

According to Standard 15, a VRF system is classified as a direct system/high-probability system where a refrigerant leak can potentially enter into the occupied space. ‘

Because the fluid is classified as a human health hazard (and is undetectable by human senses), these standards are meant to limit the potential for how much can be discharged into a single space. Institutional classifications are much stricter.

Due to the ability to displace oxygen, ASHRAE Standard 34-2013 Addendum L has established the maximum refrigerant concentration limit (RCL) of 26 lbs/1,000 ft³ of room volume for occupied spaces.



The FUTURE
of Technology

Technology for Yesterday, Today and Tomorrow

The first radiant panel systems first appeared in the Middle East in 1300 B.C., but the Romans evolved the system in 80 B.C., first using heating the floors, but eventually heating the walls as well. While extremely efficient at retaining heat, the systems were not easy to control and took an estimated two days [🔗](#) to preheat.

Modern day hydronic heating was born when a British professor, A.H. Barker, developed the radiant panel in 1907. The system was popular in England, but World War I paused broader adoption beyond Europe.

Architect Frank Lloyd Wright catapulted radiant technology into the mainstream. According to Radiant & Hydronic Magazine [🔗](#), Wright, inspired by visits to Asia, developed a “gravity heat” system, “a basic system in which a boiler located in the basement near the center of the building was plumbed with copper or steel piping that went through the slab.”

As its illustrious history shows, one of the most appealing features of hydronic systems is its future-proof compatibility. Because it operates using water, it's a safe and reliable material that will always be available to humans living on Earth.



A Future-Proof Technology

The flexibility of hydronic systems is another highly desirable characteristic. As heat source technology evolves, hydronic systems are still extremely effective as the system can pull energy from any source. This includes contemporary solar, geothermal or carbon fuel systems, along with energy sources of the future.

Expert John Siegenthaler, P.E., principal of Appropriate Designs in Holland Patent, New York, columnist for PM Magazine predicts that heat pumps will eventually become “the new boilers” in both residential and commercial hydronic systems.

“Many state energy plans are being developed around decarbonization,” Siegenthaler said in the September 2021 issue of [PM Magazine](#). “They are moving in the direction of reducing, and perhaps eventually, eliminating fossil fuels for use in heating buildings. At the same time, there are huge spending programs to encourage utility scale renewable generation of electricity (large solar farms and wind turbine farms). The most common way to use electricity for heating and cooling buildings is through use of heat pumps — of all types. Both air-to-water and geothermal water-to-water heat pumps will be increasingly used as sources for hydronic distribution systems.”

This flexibility and increased market share offers peace of mind, because in 10 years if a fan coil fails, a replacement will always be available. A fan coil, chiller or pump can be replaced anytime by any product from any manufacturer provided they meet the performance specs.

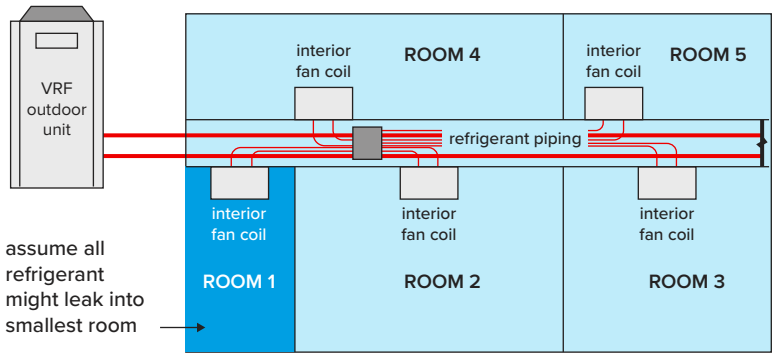

Advantages of water-based systems graphic

The flexibility of a hydronic system goes beyond the energy source. With the ability to mix and match various components, users can add features such as driveway snow melt systems, towel warmers or pool heating alongside panel radiators or other emitters used to heat and cool the building.

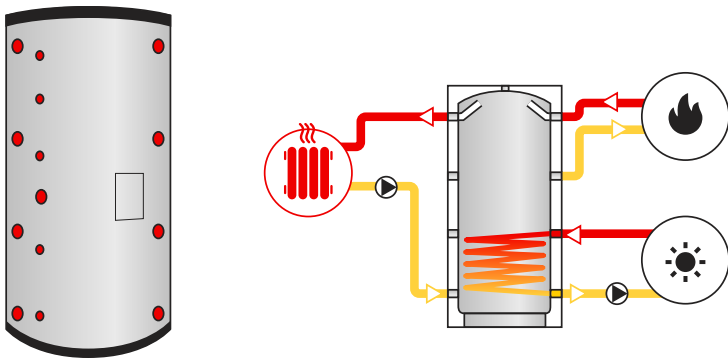

Heat Storage Tank

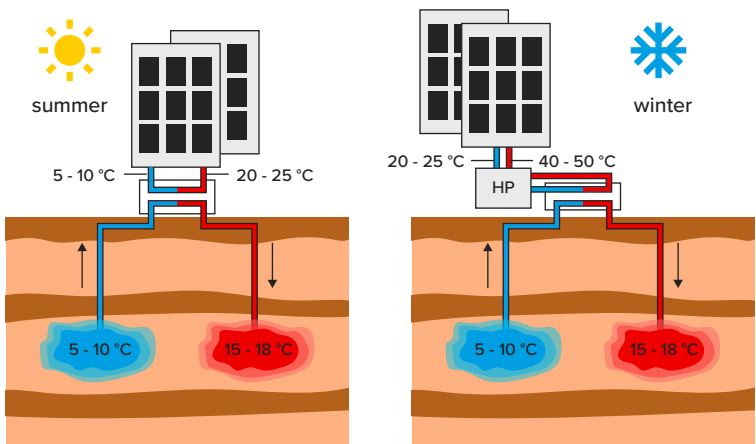

Ground source heat pump

With modern hydronic systems, energy can be buffered and stored for later use. Using thermal energy storage (TES) enables users to balance energy demands and supply on a daily, weekly and even seasonal basis. This can help reduce peak demands and overall energy consumption while increasing the overall efficiency of the system.

Future-Forward Thinking

As more engineers and building owners compare the long-term operational costs versus initial installation costs when selecting heating and cooling systems, we have experienced a greater demand for hydronic solutions. And the technology continues to improve, further reducing the amount of energy required.

For example, the coefficient of performance (COP) in air-to-water heat pumps have improved to the two or even three range. This allows the efficiency of low-temperature heat emitters to achieve even greater savings since water is 3,500 times more efficient carrying heat than air. Plus, water is 100 percent reusable.

Despite claims to the contrary, energy systems that require copper and steel piping that require large, open-pit mining is NOT a sustainable solution, even if it's the easiest to design.

As temperatures increase, we need more long-term thinking that stops the cycle of cooling that contributes to global warming. Implementing a hydronic system isn't just the right choice for now, it's also the right choice for the future.



At Jaga, we are committed to building more comfortable indoor environments while limiting our impact on the natural environment. This focus is core to everything we imagine, design and build.

From sustainable heating, cooling and ventilation products, our solutions are designed to work with environmentally friendly technology such as heat pumps and solar energy. Operating on the lowest water temperatures, our award-winning radiators not only provide outstanding heating and cooling, they enhance the space with while maximizing comfort.

For more information go to [jaga-canada.com](https://www.jaga-canada.com)