

jaga

CLIMATE DESIGNERS

Clima Canal H8

Clima Canal Hybrid H10

INSTALLATION INSTRUCTIONS

TABLE OF CONTENTS

| | |
|------------------------------------|----|
| 1. USED SYMBOLS..... | 3 |
| 2. WARNINGS AND SAFETY..... | 4 |
| 3. PACKAGING AND COMPONENTS..... | 4 |
| 4. INSTALLATION..... | 4 |
| 5. GENERAL INFORMATION..... | 5 |
| 6. PRODUCT DESCRIPTION..... | 6 |
| 7. TECHNICAL DATAT..... | 7 |
| 8. INSTALLATION..... | 9 |
| 9. INITIAL START..... | 15 |
| 10. MAINTENANCE..... | 16 |
| 11. WARRANTY..... | 17 |
| 12. DISSASSEMBLY INSTRUCTIONS..... | 17 |

DECLARATION OF CONFORMITY

CEO JAGA N.V.
Jan Kriekels



09/03/2017

JAGA N.V. - Verbindingslaan 16 - B 3590, declares under its sole responsibility that the product to which this declaration relates: **CLIMA CANAL H8, CLIMA CANAL HYBRID H10** is in conformity with the following standards or documents provided that these are used in accordance with our instructions: **NBN EN 60335-1 based on EN 60335-1:2012 + A11:2014**
NBN EN 60335-2-80 based on EN 60335-2-80:2003 + A1:2004 + A2:2009

Following the provision of Directives as amended:

- Low Voltage 2014/35/EC
- EMC 2014/30/EC
- Machinery 2006/42/EC



Jaga N.V.

As product development is a continuous process, all mentioned data are subject to change.

 **+32 (0)11 29 41 11**

1. USED SYMBOLS



the DANGER sign warns the operator and maintenance staff about risks that may cause death, physical injury or illnesses of any kind.



DANGER: ELECTRICAL HAZARD



DANGER: SHARP EDGES



DANGER: HOT SURFACES



DANGER: MOVING PARTS



ATTENTION: IMPORTANT WARNING



the ENVIRONMENTAL SAFEGUARD sign provides instructions on how to use the unit in an ECO-friendly manner.



Important info

The unit must be installed by a certified installer in accordance with the installation instructions and the local building codes. Please follow this instruction manual and file it somewhere safe! The unit must always be accessible for maintenance and inspection.

The warranty is void when:

- the installation, maintenance or operation instructions in this manual are not respected.
- modifications have been made to the product, before, during or after product installation.
- maintenance has been carried out by unauthorized people.
- maintenance has been carried out by someone other than Jaga.
- access to the unit has been restricted due to on-site conditions.
- the initial start-up has been carried out before a general cleaning of both the fan and the coil.

2. WARNINGS AND SAFETY

Handling guidelines:

The unit must be handled with care in order to avoid damage to the unit's interior and exterior parts. The unit might have sharp edges; use gloves during installation/adjustment. All the operations listed below must be carried out in accordance with local health and safety regulations.

Storage conditions:

Up to four packaged units may be stacked on top of each other. All units must be stored in a dry area.

Technical spaces and positioning:



Incorrect installation of the unit may cause noise and vibrations issues.

3. PACKAGING AND COMPONENTS

Follow these instructions when removing the packaging:

- check for any visible damage
- open the packaging
- check if the manual is in the package
- remove the packaging material and put it in the appropriate collection point or recycling facility, in compliance with the local regulations.



Dispose of the packaging materials in compliance with the national or local regulations.



Do not leave the packaging within reach of children.

4. INSTALLATION

- installation must be carried out by certified technicians. Incorrect installation could cause product failure, a reduced performance or an increased noise level.
- the unit must be installed in accordance with the local building codes.
- Always use personal protective equipment.
- the unit must remain accessible for inspection and maintenance, the trench must be removable at all times.

4.1. ACOUSTIC INSULATION

Sound absorption

Sound is reflected by hard materials. Soft, porous materials are best suited for sound absorption. A combination of different materials can reduce the reflection of sound.

Contact noise insulation

Sound travels very easily through hard materials. Soft rubber material can be used to reduce contact noise. The effect of this insulation strongly depends on:

- installation method: make sure that vibrations cannot be transferred between different elements, e.g. between the built-in heaters and other metallic parts, through pipes, along air ducts etc.
- installation of acoustic insulation in hollow acoustic spaces. Avoid cavities between insulation and pipes.

5. GENERAL INFORMATION



DANGER!

The unit is not intended for industrial applications.
Do not insert objects into the supply and return air openings.



IMPORTANT!

- the unit will only function correctly if the installation and operation manual is strictly followed.
- all clearances indicated in the manual must be respected in order to guarantee performance, and to allow installation and maintenance.
- in case valve packages are to be installed, make sure that there is enough room left.
- periodic access to the unit is required for inspection, maintenance and repairs.
- pay attention to the signs and symbols indicated on the fan coil units.

Unit identification:

The serial number is tagged on unit's right side (on the left if the connections are on the unit's right side).

Information regarding unintended use:

The unit has been designed to function as a fan coil for both heating and cooling applications; any other use is strictly forbidden. Installing the unit in an explosive environment is prohibited.

Decommissioning:

When the unit is not used for long periods of time, it must be disconnected from the mains electrical connection.

If the unit is not used during the winter period, the water in the system may freeze. A suitable quantity of anti-freeze liquid should be mixed with the water.



Mixing the water with glycol modifies the unit's performance. Pay attention to the safety instructions on the packaging regarding glycol.

Restart after prolonged shutdown:

Before restarting:

- clean or replace the stainless steel fan guard.
- clean the coil.
- clean or unclog the condensate drain.
- bleed the air from the hydronic system.
- it is advisable to run the unit at maximum speed and to check for abnormalities.

6. PRODUCT DESCRIPTION

The Clima Canal is simultaneously a powerful heater, cooling unit and ventilation system. The dynamic high-tech 2-pipe coil and the thermal fan ensures that the switch-over from heating to cooling is effortless. These units are specially designed to emit a lot of heat and the cooling goes well with both sensible and total cooling systems. By making use of the latest EC-motors, the Clima Canals consume 50% less power. Moreover, these motors can be controlled through home automation.

6.1. OVERVIEW OF THE DIFFERENT PARTS

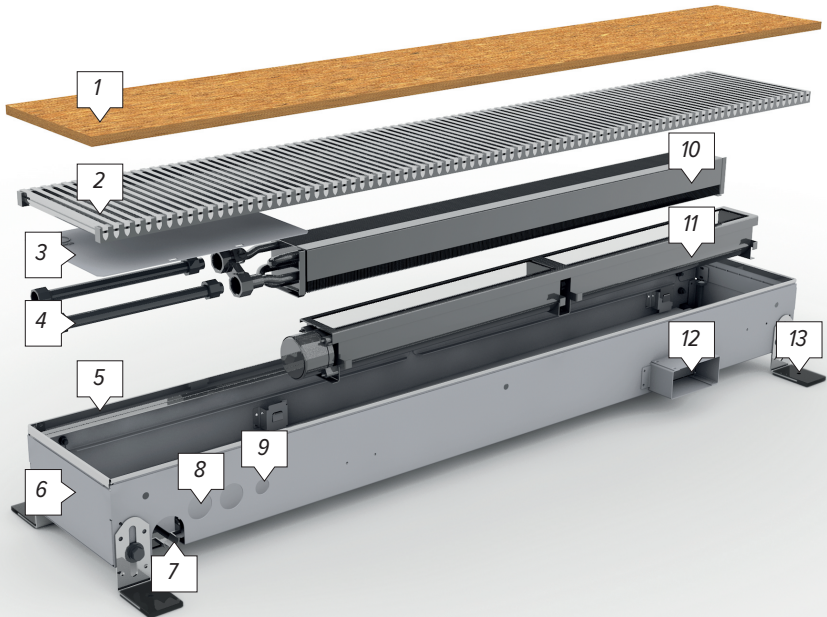

1. Protective cover
2. Grille
3. Valve cover plate
4. Stainless steel flexible connectors 1/2"
5. Internal height adjustment
6. Trench
7. Condensate drain

8. Hydraulic connection (always on the left hand side)
9. Electrical connection (always on the left hand side)
10. 2-pipe dynamic coil
11. Tangential fan
12. Ventilation system connection
13. External height adjustment with acoustic insulation

7. TECHNICAL DATA

7.1. DIMENSIONS H8 / H10

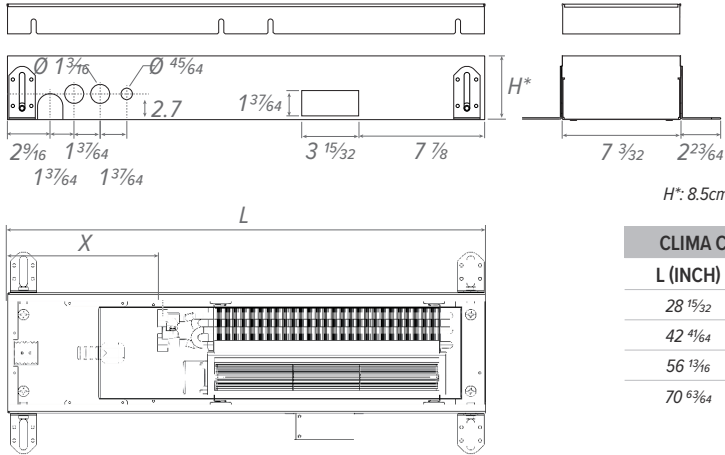

7.2. DIMENSIONS- STANDARD HEIGHT ADJUSTMENT

Standard height adjustments H8 / H10



7.3. DIMENSIONS – HEIGHT ADJUSTMENT WITH RAISED FLOORS

Option: adjustable raised floor pedestals H8 / H10

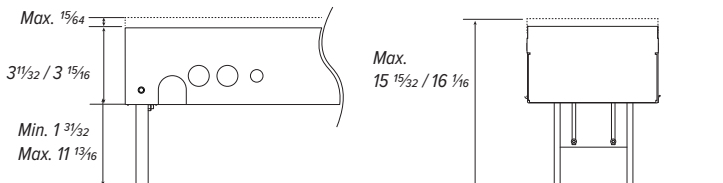

7.4. LEAVE SOME ROOM

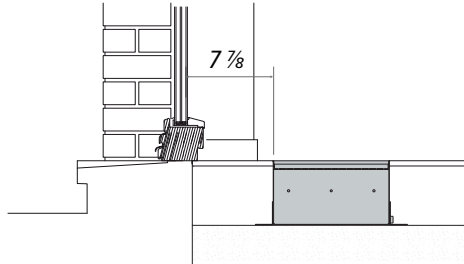

! When installing the trench fancoil in front of a window, make sure to allow sufficient space for curtains. The curtain should never cover the grill of the trench fancoil unit.

7.5. MAX CABLE LENGHT - 24 VDC ELECTRICAL CONNECTION

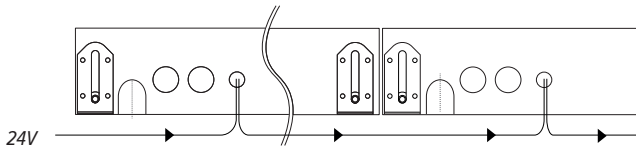

| DISTANCE FROM POWER SUPPLY IN FT. | 30 | 60 | 100 | 130 | 160 | 200 | 230 | 260 | 300 | 330 |
|-----------------------------------|---------------------------------------------|----|-----|-----|-----|-----|-----|-----|-----|-----|
| Ø | TYPE 1 (8.4W) NUMBER OF CLIMA CANALS | | | | | | | | | |
| 17 AWG | 18 | 9 | 6 | 4 | | | 3 | | 2 | 1 |
| 16 AWG | 28 | 14 | 9 | 7 | | 5 | 4 | 3 | 2 | 1 |
| 14 AWG | 47 | 23 | 15 | 11 | 9 | 7 | | 6 | | 5 |
| Ø | TYPE 2 (14W) NUMBER OF CLIMA CANALS | | | | | | | | | |
| 17 AWG | 12 | 6 | 4 | 3 | | | | 2 | | |
| 16 AWG | 18 | 9 | 6 | 4 | | | 3 | | | 2 |
| 14 AWG | 30 | 15 | 10 | 7 | 6 | 5 | | 4 | | 3 |
| Ø | TYPE 3 (22W) NUMBER OF CLIMA CANALS | | | | | | | | | |
| 17 AWG | 8 | | 4 | | | 2 | | | | 1 |
| 16 AWG | 12 | 6 | 4 | | 3 | | | 2 | | |
| 14 AWG | 20 | 10 | 6 | 5 | 4 | 3 | | | 2 | |
| Ø | TYPE 4 (28W) NUMBER OF CLIMA CANALS | | | | | | | | | |
| 17 AWG | 6 | 3 | | 2 | | 1 | | | | |
| 16 AWG | 10 | 5 | | 3 | | | 2 | | | 1 |
| 14 AWG | 17 | 8 | 5 | 4 | | 3 | | | 2 | |

8. INSTALLATION

⚠ ALWAYS SWITCH OFF THE MAINS SUPPLY BEFORE INSTALLATION

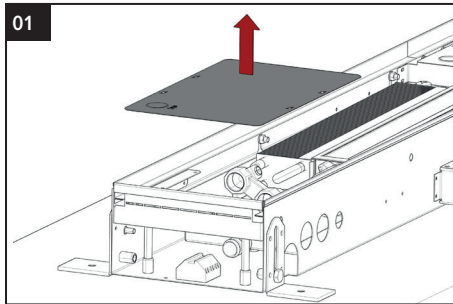

01 Remove the valve cover plate before installing the device.

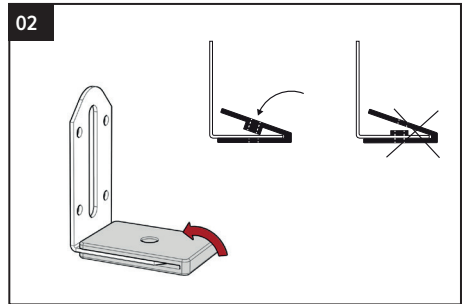

02 Fit the brackets with the acoustic insulation.

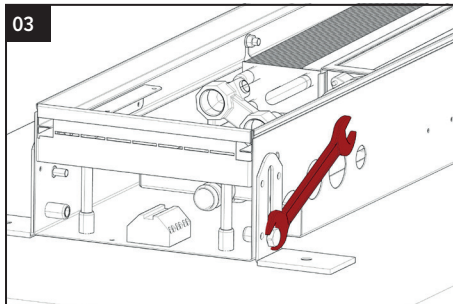

03 Secure the brackets to the outer trench (but do not completely tighten).

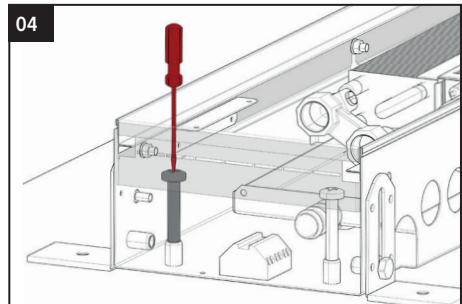

04 Screw the adjustment screws in the bottom of the trench and place the caps on top of the screws.

If different clima canals need to be interlocked, then proceed to step 05.

If you are installing a single unit, proceed to step 07.

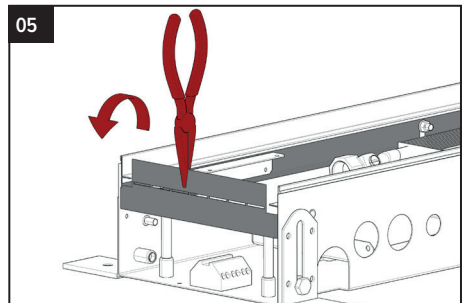

05 Break off the metal piece on the trench's short end (to allow continuous installation).

⚠ Only on the ends that will be connected to another unit.

06

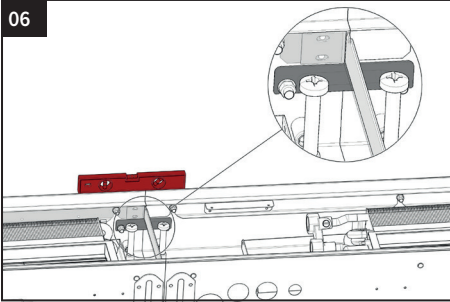

Make sure that the unit is correctly positioned and that grille holders are tightly connected. Use the provided connectors to connect the different units with each other.

07

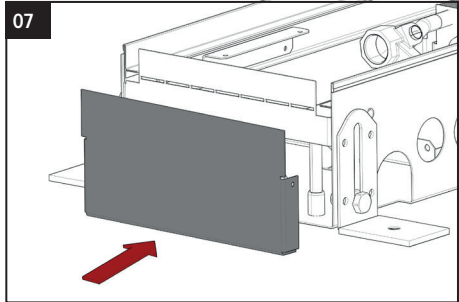

Place the ends on the sides.

08

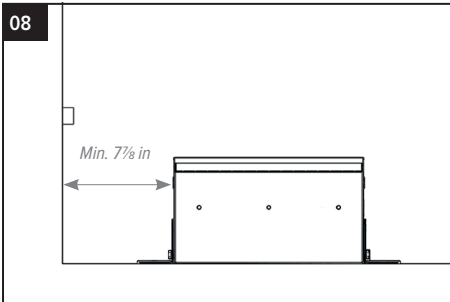

Position the units correctly, with the coil towards the wall.

⚠ Position the unit at a distance of at least 20 cm from the window wall.

09

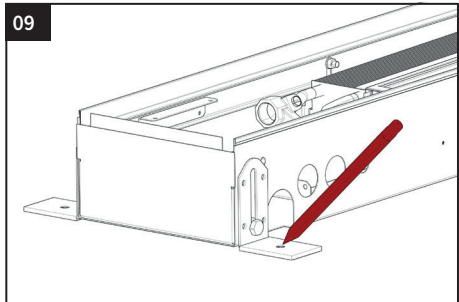

Mark the drill holes. Drill the holes (drill dia. 8mm) and insert the plugs.

⚠ Make sure to use the correct type of plug for your floor type!

10

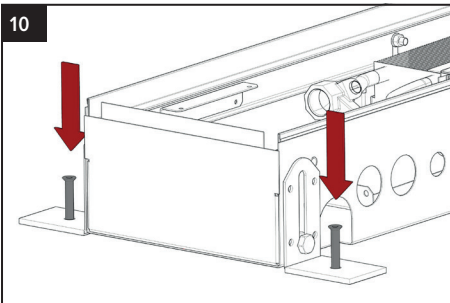

Secure the unit to the floor by means of the acoustically insulated brackets.

11

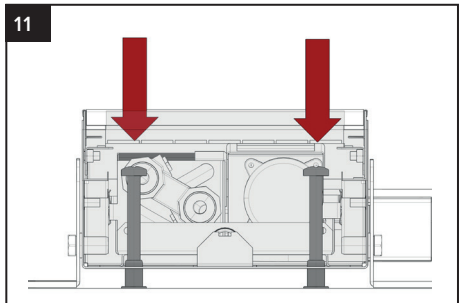

Use the adjustment-screws to adjust the unit's height. Make sure that the top is level with the finished floor.

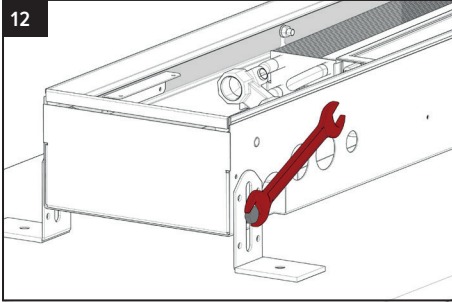

Secure the brackets. Final adjustment to be done with screws.

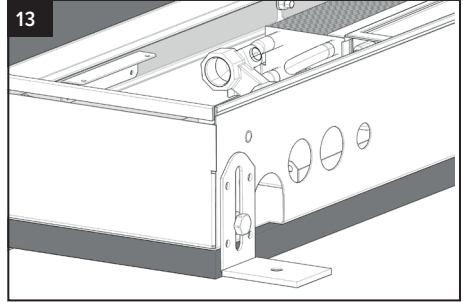

Fill the cavities under the trench with a solid mass.

8.1. HYDRAULIC CONNECTION

An overview of the incoming hydraulic connections and their connection to the coil.

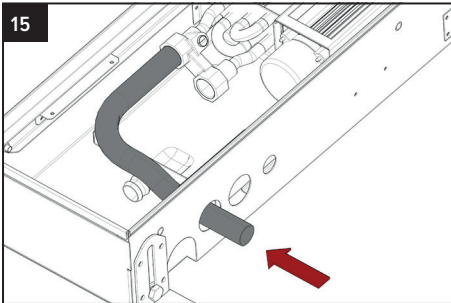
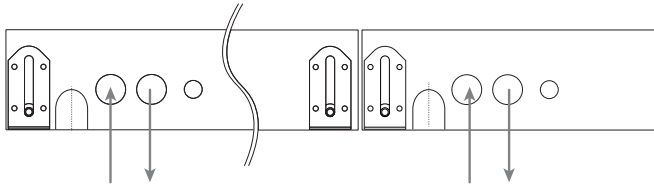

Connect the flexible hose connectors to the coil's supply connection.

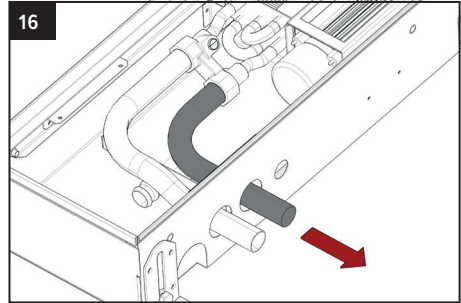

Connect the flexible hose connectors to the coil's return connection.

8.2. CONNECTING THE CONDENSATE DRAIN- H10 ONLY

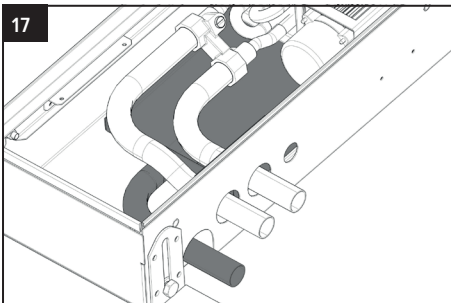

Make sure that the condensate water is properly drained and keep the condensate drain clean and unclogged. The condensate drain must not be subjected to mechanical strain.

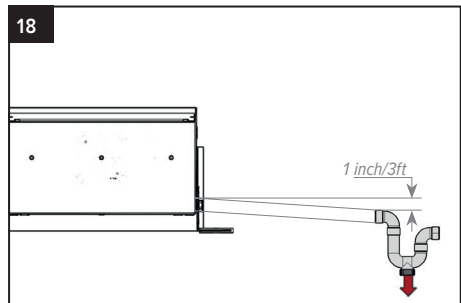

The condensate drain must be fitted with a P-trap. Pour water in the condensate drain tray to see if it drains properly. If not, check the slope

8.3. ELECTRICAL CONNECTION

 For the general safety instructions see: warnings and safety- p. 5

 SHUT OFF THE MAINS SUPPLY BEFORE CONNECTING

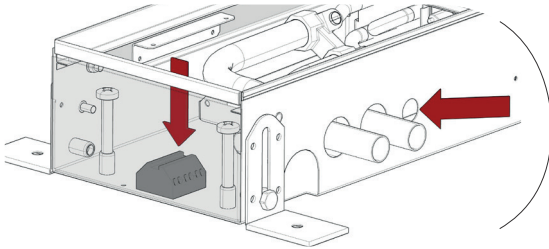

The electrical connection is on the same side as the hydraulic connections.

8.3.1. Standard electrical connections without thermoelectric motor:

[A] and [B] need to be connected to the unit's electrical box.

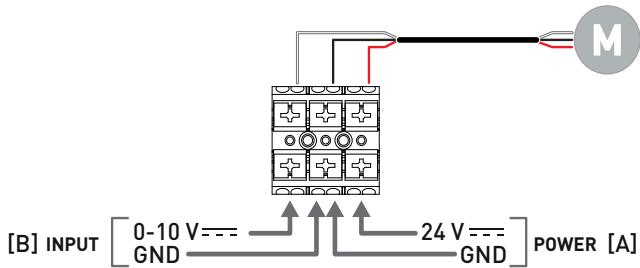

8.4. FINISHING THE INSTALLATION BEFORE LAYING THE FLOOR

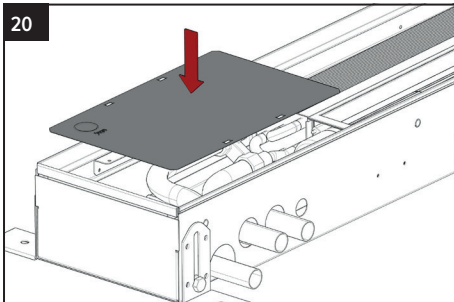

Assemble the valve cover plate and cover the trench with the protective cover and the foil.

! This protective cover must remain on the unit during the entire installation.

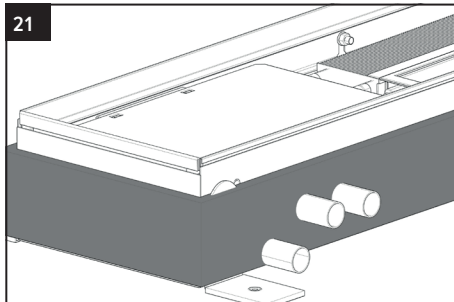

With screed (concrete or cement), edge insulation will have to be installed around the unit in order to protect it from the stress caused by the heating and the cooling.

8.5. FINISHING THE INSTALLATION AFTER LAYING THE FLOOR

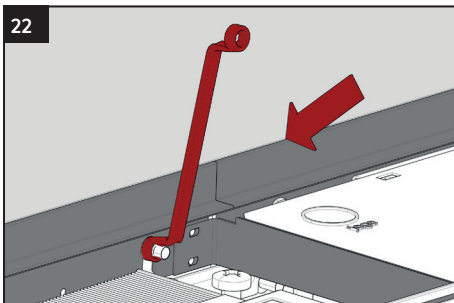

Final adjustment: max. 0.8cm for perfect alignment with the finished floor.

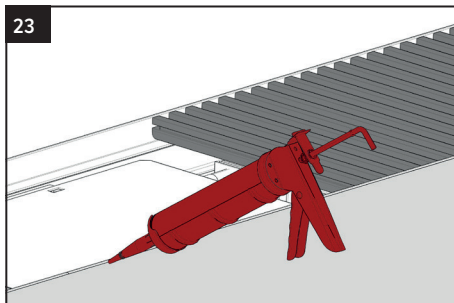

After placing the subfloor and the finished floor: remove the protective cover and the foil, place the grille and then apply the finishing touches

9. INITIAL START



IMPORTANT!

Start-up and Commissioning of the fancoil must be carried out by skilled staff, qualified to work on this type of product.



DANGER!

Before start-up, make sure the installation has been carried out in compliance with in this manual.

Before start-up the fancoil unit, check if:

1. the unit is positioned correctly
2. the supply and return pipes are properly connected and insulated
3. the pipes are clean and air is removed
4. the inclination of the unit towards the drain and the p-trap are correct
5. the coils are clean
6. the wiring connections are correct and properly tightened
7. the supply voltage is correct
8. the electric power consumption is correct and does not exceed the maximum value indicated in the catalog

Run the fan for minimal 3 hours and check for abnormalities.

10. MAINTENANCE



DANGER!

- maintenance must be carried out by qualified technicians.
- do not insert sharp objects into the supply and return grilles
- the unit has sharp edges; use gloves during maintenance!



DANGER!

Always use the main disconnect switch to isolate the unit from the mains before carrying out any maintenance or inspection work. Make sure that no one accidentally turns on the power to the unit; lock the master switch in the off position.

10.1. SPECIAL NOTE

Maintenance and cleaning of the stainless steel protection grille:

a dirty grille obstructs the air flow, so clean the grille at regular intervals, depending on the room's purpose and how it's used. The grille should never be disassembled for maintenance and can be easily cleaned by using a vacuum cleaner.

Cleaning the unit:

always disconnect the power supply before servicing the fan!!

- cleaning at regular intervals is important, depending on the room's purpose and how it's used
- clean with a vacuum cleaner or air compressor. Do not use solvent- or detergent based products.

10.2. ROUTINE MAINTENANCE

Every 6 months: Check the condition of the coil and condensate drain:

If necessary:

- remove any dirt from the coil surface
- remove dust using an air compressor
- wash with water and brush gently
- dry by using compressed air
- keep the condensate drain free from any obstructions that may prevent normal water flow

Bleed air from the system.

1. start the circulation pump and open the supply valve for a few minutes.
2. stop the circulation pump.
3. loosen the vent screw on the inlet collector and bleed the air.
4. repeat steps 1 to 3 until there is no more air escaping the system

10.3. ELECTRICAL CIRCUIT

The following steps are recommended to perform maintenance on the electrical circuit:

- check the unit's power consumption using a clip-on meter and compare the reading with the values shown in the documentation;
- inspect the electrical contacts for corrosion and loose wires.

11. WARRANTY

The fan coil unit is intended strictly for conditioning the indoor climate. Any unintended use is strictly forbidden and voids all warranty on the product. Installation, maintenance and operation of the unit is only allowed for authorized staff.

Please follow these instructions carefully

The warranty is void when:

- the installation procedure has not been followed,
- the fan coil has not been periodically cleaned,
- the unit has been used in an improper or irresponsible manner,
- repairs have been carried out by others than Jaga,
- product modifications have been carried out by others, before or after the installation,
- the product is not accessible for cleaning or maintenance.

If you have any questions or complaints, please contact your supplier or installer. The copyright of these instructions is the property of Jaga.

12. DISSASSEMBLY INSTRUCTIONS



SAFEGUARD THE ENVIROMENT

Jaga cares about protecting the environment.

When the unit is dismantled it is important to strictly follow these procedures:

- the unit must be dismantled by a firm that is authorized to dispose of scrap machinery/products

The unit as a whole is composed of secondary raw materials and the following conditions must be met:

- if the unit contains antifreeze, then dispose of the antifreeze as indicated in the glycol supplier's instructions.
- the electronic components are considered special waste, and must be recycled as such
- the pipe insulation and the sound-absorbing lining must be removed and processed as urban waste

Please follow and file these instructions!

NOTES

NOTES

Jaga Canada Climate Systems
www.jaga-canada.com

december 20, 2018 2:46 p.m. - Jaga Inc.