

jaga CLIMATE DESIGNERS

BRIZA 26 HIGH PERFORMANCE

MANUAL

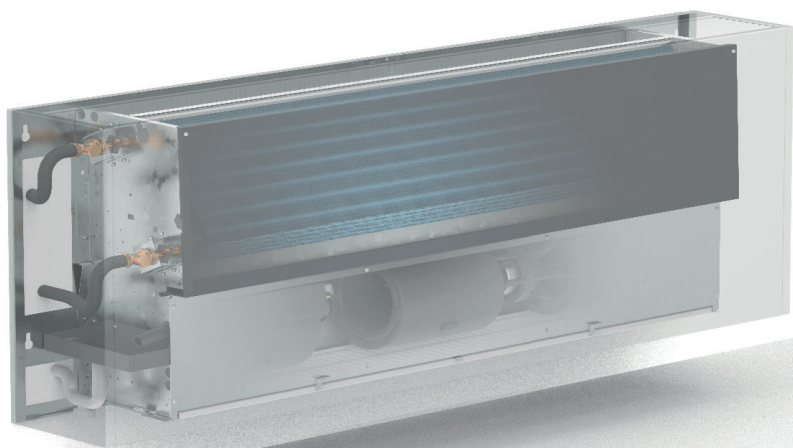

TABLE OF CONTENTS

- 1. USED SYMBOLS 3
- 2. WARNINGS AND SAFETY 4
- 3. PACKAGING AND COMPONENTS 4
- 4. INSTALLATION 4
 - 4.1. ACOUSTIC INSULATION 4
- 5. GENERAL INFORMATION 5
 - 5.1. OPERATIONAL LIMITS: 5
 - 5.2. ELECTRICAL CONNECTION - GENERAL 6
 - 5.3. OPERATING LIMITS 7
- 6. WALL MOUNTED MODEL 8
 - 6.1. OVERVIEW 8
 - 6.2. CONFIGURATION 8
 - 6.3. DIMENSIONS 9
- 7. INSTALLATION 11
- 8. CEILING-MOUNTED-MODEL 15
 - 8.1. OVERVIEW 15
 - 8.2. CONFIGURATION 15
 - 8.3. DIMENSIONS 16
 - 8.4. INSTALLATION 17
- 9. INITIAL START 19
- 10. MAINTENANCE 19
 - 10.1. SPECIAL NOTE 19
 - 10.2. ROUTINE MAINTENANCE 19
 - 10.3. ELECTRICAL CIRCUIT 20
- 11. WARRANTY 20
- 12. DISSASSEMBLY INSTRUCTIONS 20
- 13. REFERENCE STANDARDS 21

DECLARATION OF CONFORMITY

CEO JAGA N.V.
Jan Kriekels



08/02/2022

JAGA N.V. - Verbindingslaan 16 - B 3590, declares under its sole responsibility that the product to which this declaration relates: **BRIZA 12, BRIZA 22, BRIZA 26** is in conformity with the following standards or documents provided that these are used in accordance with our instructions: **NBN EN 60335-1 BASED ON EN 60335-1:2012 + A11:2014 + A12:2017 + A13:2017 + A1:2019 + A2:2019 + A14:2019**
NBN EN 60335-2-80 BASED ON EN 60335-2-80:2003 + A1:2004 + A2:2009

Following the provision of Directives as amended:
 - Low Voltage 2014/35/EC - Machinery 2006/42/EC
 - EMC 2014/30/EC - RoHS 2011/65/EU



1. USED SYMBOLS



the DANGER sign warns the operator and maintenance staff about risks that may cause death, physical injury or illnesses of any kind.



DANGER: ELECTRICAL HAZARD



DANGER: SHARP EDGES



DANGER: HOT SURFACES



DANGER: MOVING PARTS



ATTENTION: IMPORTANT WARNING



the ENVIROMENTAL SAFEGUARD sign provides instructions on how to use the unit in an ECO-friendly manner.



Important info

The unit must be installed by a certified installer in accordance with the installation instructions and the local building codes. Please follow this instruction manual and file it somewhere safe! The unit must always be accessible for maintenance and inspection.

The warranty is void when:

- the installation, maintenance or operation instructions in this manual are not respected.
- modifications have been made to the product, before, during or after product installation.
- maintenance has been carried out by unauthorized people.
- maintenance has been carried out by someone other than Jaga.
- access to the unit has been restricted due to on-site conditions.
- the initial start-up has been carried out before a general cleaning of both the fan and the coil.

2. WARNINGS AND SAFETY

Handling guidelines:

The unit must be handled with care in order to avoid damage to the unit's interior and exterior parts. The unit might have sharp edges; use gloves during installation/adjustment.

All the operations listed below must be carried out in accordance with local health and safety regulations.

Storage conditions:

Up to four packaged units may be stacked on top of each other. All units must be stored in a dry area.

Technical spaces and positioning:



Incorrect installation of the unit may cause noise and vibrations issues.

3. PACKAGING AND COMPONENTS

Follow these instructions when removing the packaging:

- check for any visible damage
- open the packaging
- check if the manual is in the package
- remove the packaging material and put it in the appropriate collection point or recycling facility, in compliance with the local regulations.



Dispose of the packaging materials in compliance with the national or local regulations.



Do not leave the packaging within reach of children.

4. INSTALLATION

- installation must be carried out by certified technicians. Incorrect installation could cause product failure, a reduced performance or an increased noise level.
- the unit must be installed in accordance with the local building codes.
- Always use personal protective equipment.
- the unit must remain accessible for inspection and maintenance, the trench must be removable at all times.

4.1. ACOUSTIC INSULATION

Sound absorption

Sound is reflected by hard materials. Soft, porous materials are best suited for sound absorption. A combination of different materials can reduce the reflection of sound.

Contact noise insulation

Sound travels very easily through hard materials. Soft rubber material can be used to reduce contact noise. The effect of this insulation strongly depends on:

- installation method: make sure that vibrations cannot be transferred between different elements, e.g. between the built-in heaters and other metallic parts, through pipes, along air ducts etc.
- installation of acoustic insulation in hollow acoustic spaces. Avoid cavities between insulation and pipes.

5. GENERAL INFORMATION



DANGER!

The unit is not intended for industrial applications.
Do not insert objects into the supply and return air openings.



IMPORTANT!

- the unit will only function correctly if the installation and operation manual is strictly followed.
- all clearances indicated in the manual must be respected in order to guarantee performance, and to allow installation and maintenance.
- in case valve packages are to be installed, make sure that there is enough room left.
- periodic access to the unit is required for inspection, maintenance and repairs.
- pay attention to the signs and symbols indicated on the fan coil units.

Unit identification:

The serial number is tagged on unit's right side (on the left if the connections are on the unit's right side).

Information regarding unintended use:

The unit has been designed to function as a fan coil for both heating and cooling applications; any other use is strictly forbidden. Installing the unit in an explosive environment is prohibited.

Decommissioning:

When the unit is not used for long periods of time, it must be disconnected from the mains electrical connection.

If the unit is not used during the winter period, the water in the system may freeze. A suitable quantity of anti-freeze liquid should be mixed with the water.



Mixing the water with glycol modifies the unit's performance. Pay attention to the safety instructions on the packaging regarding glycol.

Restart after prolonged shutdown:

Before restarting:

- clean or replace the stainless steel fan guard.
- clean the coil.
- clean or unclog the condensate drain.
- bleed the air from the hydronic system.
- it is advisable to run the unit at maximum speed and to check for abnormalities.

5.1. OPERATIONAL LIMITS:

An installation that does not meet the specified operational limits releases Jaga NV from all liability with respect to damage to objects or people.

- mains voltage: 208V - 1 ph - 60Hz
- maximum water inlet temperature: 90°C - 194°F
- maximum exchanger pressure: 20 bar - 290PSI
- supply voltage: 208V ±10 %

5.2. ELECTRICAL CONNECTION - GENERAL

IMPORTANT!

The electrical connection of the unit must be carried out by qualified personnel, in compliance with the regulations applicable in the country where the unit is installed. Non-conforming electrical connections releases Jaga N.V. from liability concerning damage to objects and persons.

DANGER!

- Always install a general automatic switch in a protected area near the unit, which has a characteristic delayed curve, sufficient capacity and breaking power. There must be a minimum distance of 3 mm between the contacts.
- Earth connection is compulsory by law to ensure user safety while the unit is in use.
- Check that the voltage and the frequency of the electrical system correspond to 208V ($\pm 10\%$) single phase at 60Hz; that the available installed power is sufficient for running the equipment and that the supply cables are of adequate section for the maximum current required.
- Make sure the electrical supply system complies with current National safety regulations.
- The connections must be implemented in accordance with the diagrams supplied with the unit.
Use an H05RN-F type, flexible, double insulated, bipolar + earth cable with a 1.5 mm² section to connect the unit to the mains.
- If the unit is mounted on a metal surface, the earth connection must be installed in compliance with local regulations. The earth conductor must be longer than the other conductors so that it is the last one to release in the event the connection comes loose.

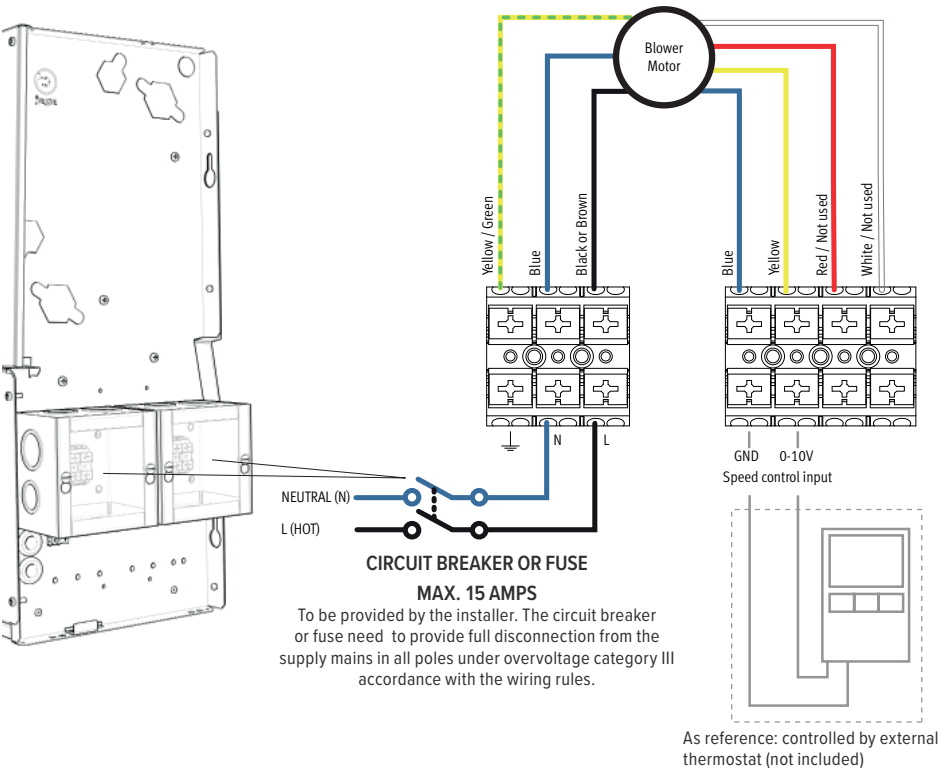

5.3. OPERATING LIMITS

If the appliance is supplied with chilled water, the condensation forming on the heat exchanger will be drained via the condensation drain connection.

At very low chilled water temperature and very high humidity, condensation may form on components other than the heat exchanger. This is not collected in the condensation drain, but might drip from under the appliance.

To avoid this, a minimum permitted water temperature must be taken into account in function of the relative humidity and temperature of the ambient air.

5.3.1. PERMITTED MINIMUM WATER TEMPERATURE (°C)

		AMBIENT TEMPERATURE / DRY BULB TEMPERATURE (°F)					
		69.8 °F	73.4 °F	77 °F	80.6 °F	84.2 °F	87.8 °C
RH (%)	40 %	37.4 °F	37.4 °F	37.4 °F	37.4 °F	37.4 °F	39.2 °F
	50 %	37.4 °F	37.4 °F	37.4 °F	37.4 °F	39.2 °F	42.8 °F
	60 %	37.4 °F	37.4 °F	39.2 °F	39.2 °F	42.8 °F	46.4 °F
	70 %	37.4 °F	39.2 °F	41 °F	42.8 °F	46.4 °F	50 °F
	80 %	39.2 °F	41 °F	42.8 °F	46.4 °F	50 °F	/
	90 %	41 °F	42.8 °F	46.4 °F	50 °F	/	/
	100 %	42.8 °F	46.4 °F	50 °F	/	/	/

Permitted minimum water temperature

EN

6. WALL MOUNTED MODEL

6.1. OVERVIEW

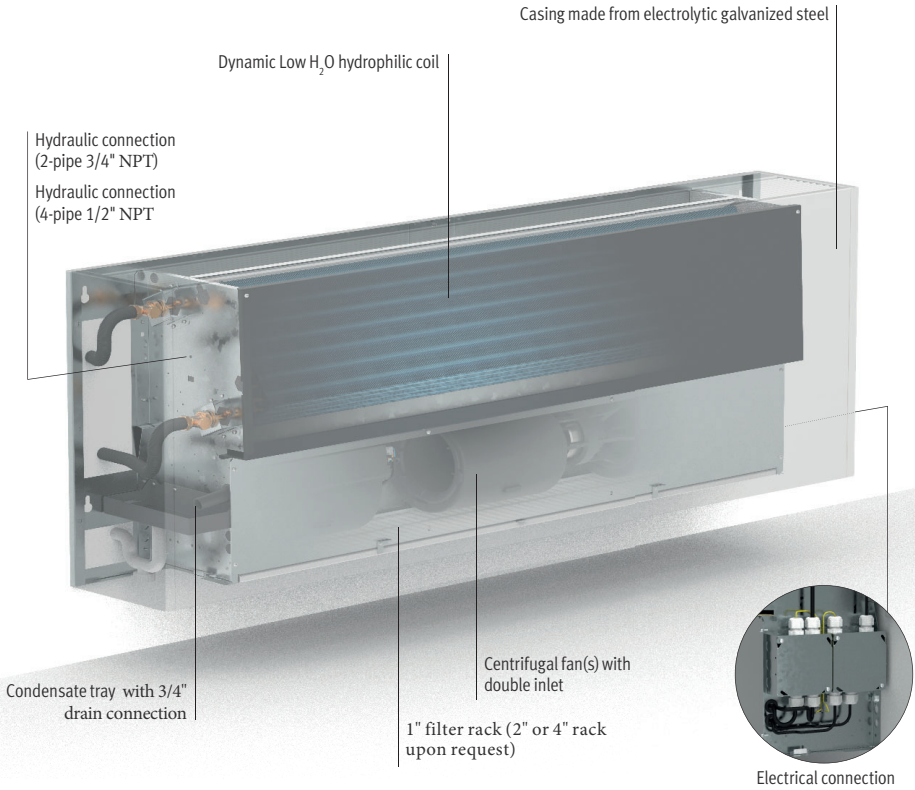

6.2. CONFIGURATION

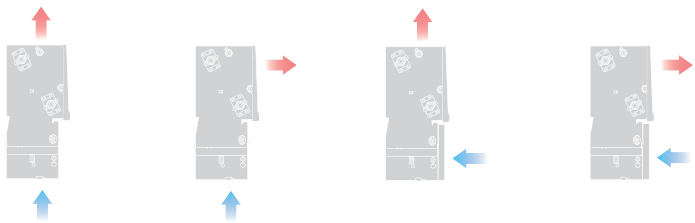

	BABW/BT	BABW/BF	BABW/FT	BABW/FF
SUCTION	the bottom of the unit	the bottom of the unit	the front of the unit	the front of the unit
AIR OUTLET	the top of the unit	the front of the unit	the top of the unit	the front of the unit

6.3. DIMENSIONS

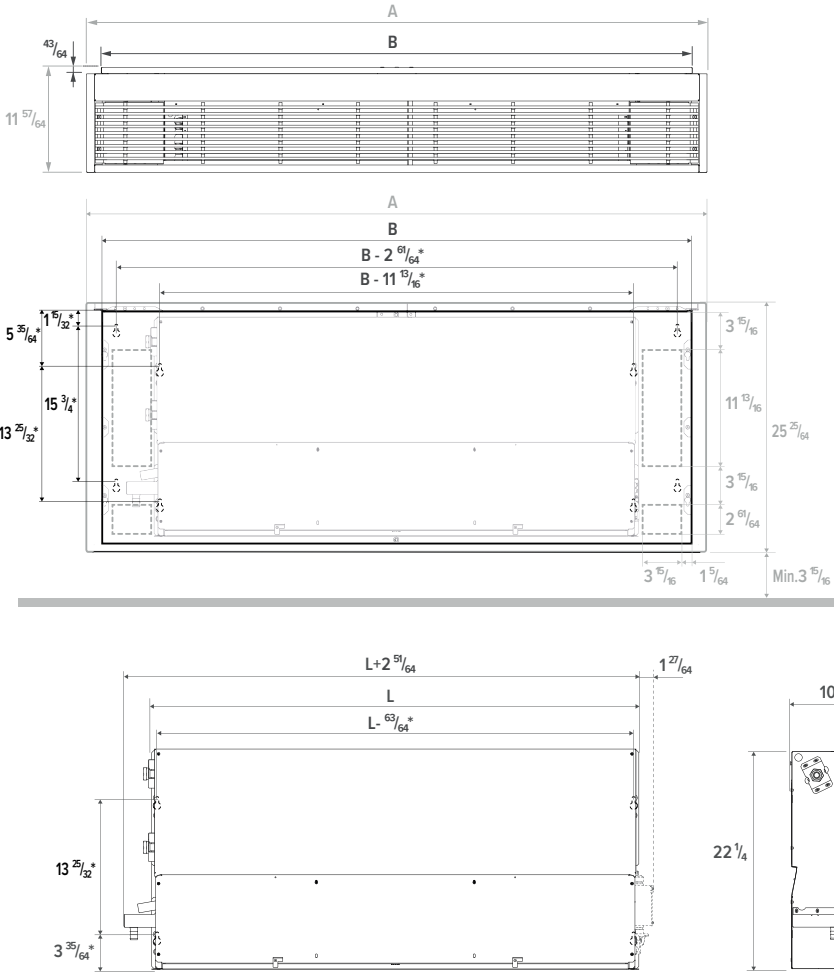

EN

Dimensions in Inches

	T6	T8	T10
L	$49 \frac{7}{32}$	$59 \frac{1}{16}$	$74 \frac{51}{64}$
HEIGHT	$22 \frac{1}{4}$	$22 \frac{1}{4}$	$22 \frac{1}{4}$
WIDTH	$10 \frac{19}{32}$	$10 \frac{19}{32}$	$10 \frac{19}{32}$
LENGTH	$52 \frac{1}{64}$	$63 \frac{13}{16}$	$77 \frac{19}{32}$
A	$62 \frac{63}{64}$	$74 \frac{51}{64}$	$88 \frac{37}{64}$
B	$60 \frac{3}{64}$	$71 \frac{27}{32}$	$85 \frac{5}{8}$

6.3.1. Installation dimensions

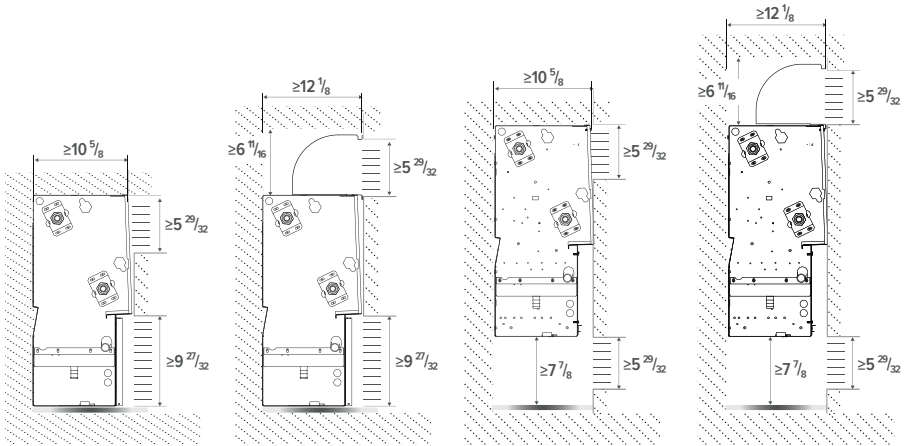
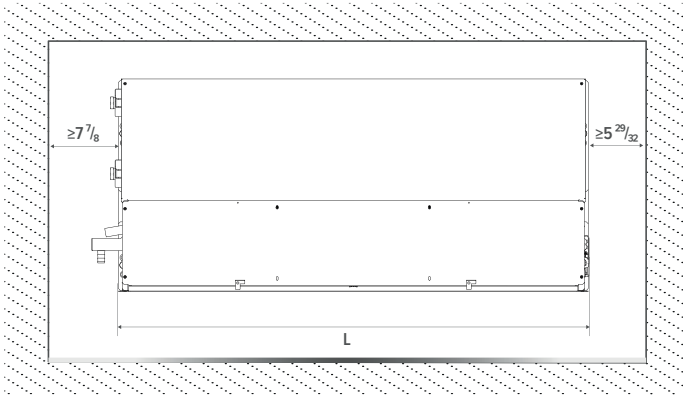

Dimensions in Inches

6.3.2. Hydraulic & electrical connection

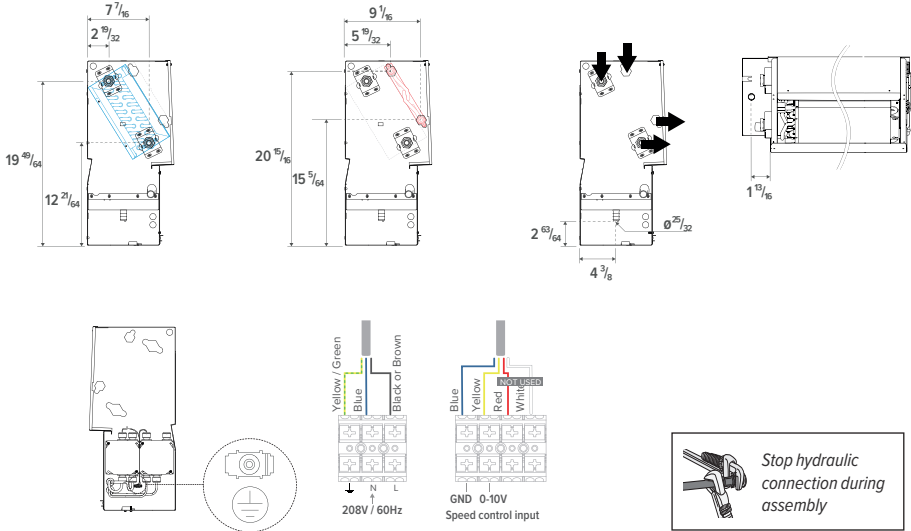

Dimensions in Inches

7. INSTALLATION

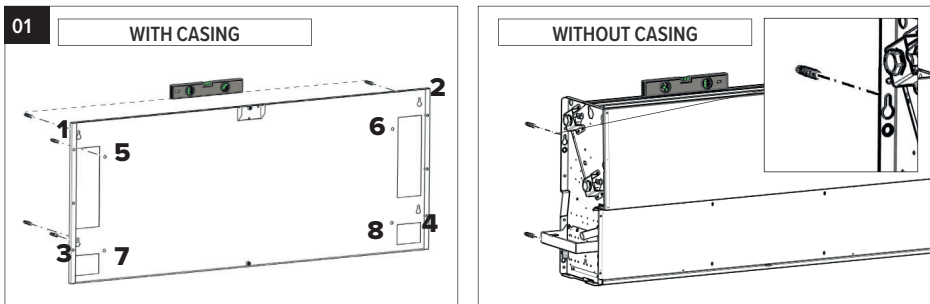

With casing: Mark and drill the mounting holes for the back plate and the device (1-8).

Without casing: Mark and drill the mounting holes for the the device.

The type of wall determines which type of screw or plug must be used.

⚠ Make sure that the wall is level and has sufficient loadbearing capacity!

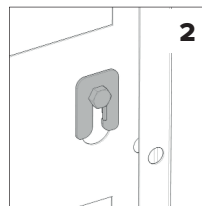
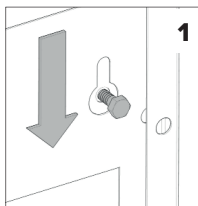
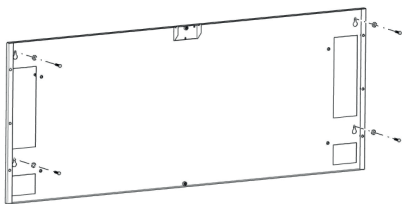
02**WITH CASING**

1. Insert the screws of the back plate (1-4) and let them stick out 1 cm.[1]
2. Install the back plate.
3. Tighten the screws. [2]

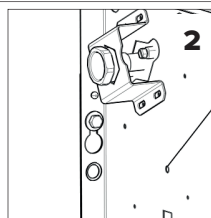
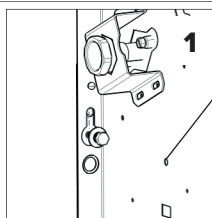
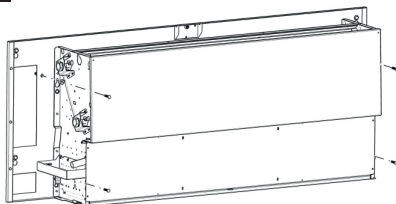
03

1. Place the screws of the device(5-8) and let them stick out 1 cm. [1]
2. Place the device in the correct position.
3. Tighten the screws. [2]

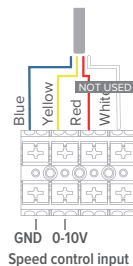
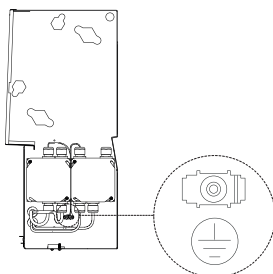
04

Connect the device electrically.

05

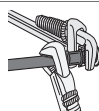
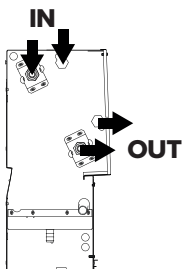

Use a back-off wrench when fastening the hydraulic connections!



Remove black plug at hydraulic connection.

Connect the device to the hydraulic system by using the specified inlet/ outlet connections. Make sure that the connections are air tight, use a sealant for this. The coil is equipped with a de-aerater.



If the unit is used for cooling, the hydraulic pipes must be insulated.

When using devices for cooling: iron couplings prohibited.

06

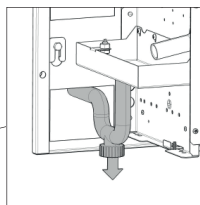
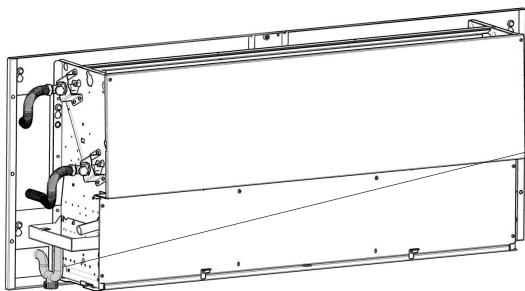

Install the condensate drain. The device must be hung with a downward slant towards the condensate drain, to ensure that the condensation water is drained quickly. (3cm/m)

The condensate drain system must be set up with an adequate p-trap in order to prevent the infiltration of odours. Always install a plug for cleaning in the lower part of the p-trap in order to allow quick disassembly. Pour water into the condensate collection pan and check if the liquid is drained properly. Otherwise, check the inclination and look for possible blockages.



If the condensation drain pan is not used, the drain pipe must be connected directly to the condensation trap. In this case, the hydraulic pipes and the valves used for cooling water must be insulated against condensation

Position the drain pipes without mechanical stress on the drain connection of the unit.

EN

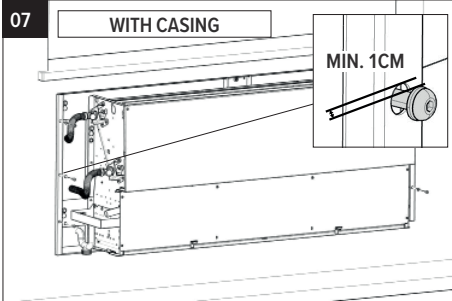

Install the support bolts in the back plate. Let the bolts stick out 1 cm.

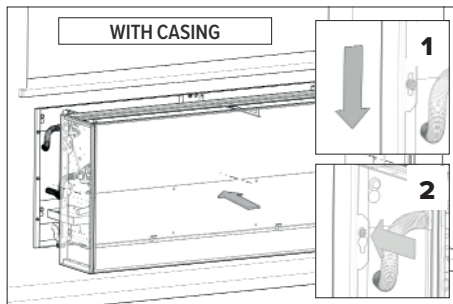

Mount the casing. Make sure the mounting holes are in line with the support bolts. [1]

Secure the casing by tightening the stay bolts. [2]

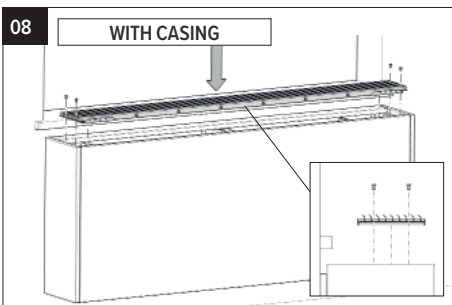

Install the grille. Put the screws in the mounting holes.

⚠ Ideally, the air is blown towards the wall.

8. CEILING-MOUNTED-MODEL

8.1. OVERVIEW

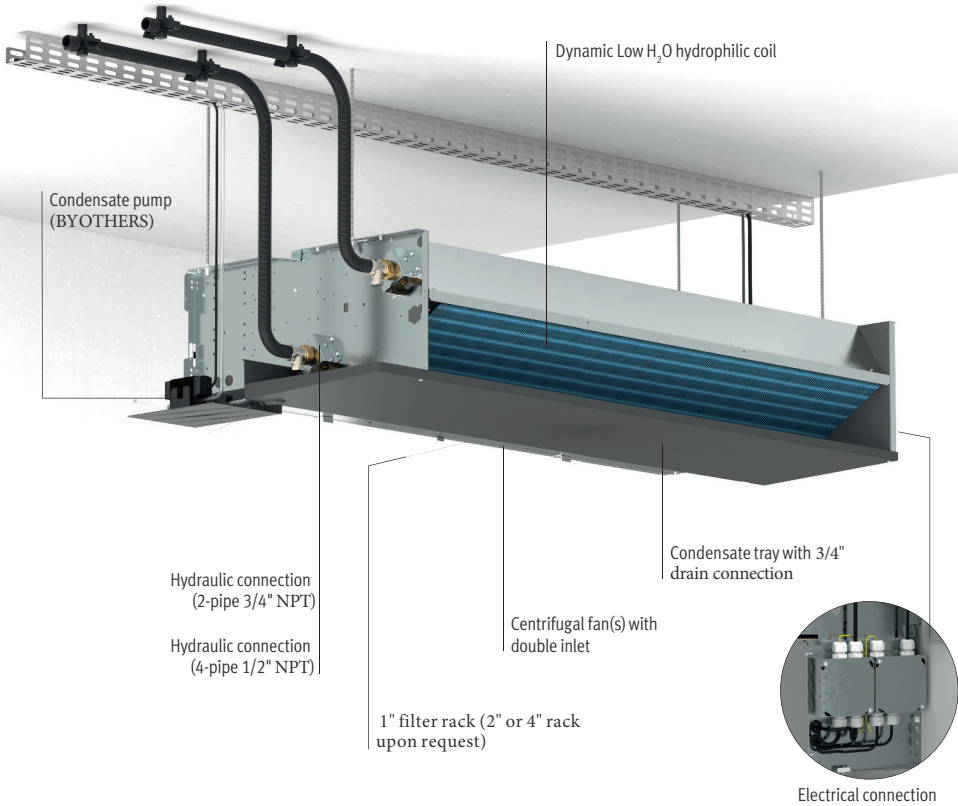

8.2. CONFIGURATION



	BABW/BT	BABW/FT
SUCTION	the bottom of the unit	the front of the unit
AIR OUTLET	the top of the unit	the top of the unit

8.3. DIMENSIONS

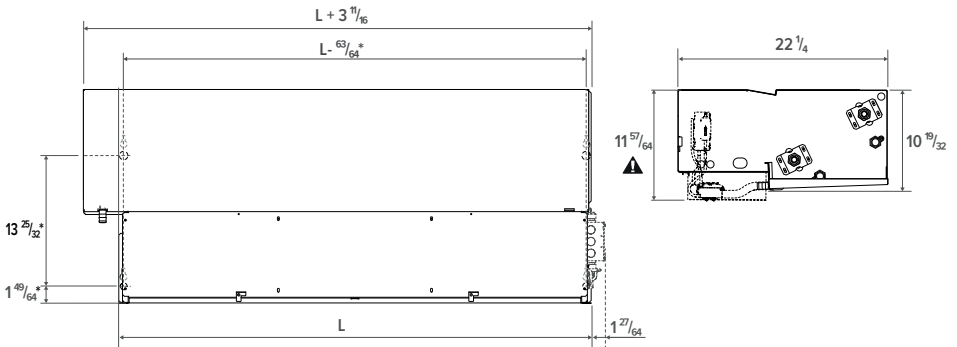

Dimensions in Inches

	T6	T8	T10
HEIGHT	22 1/4	22 1/4	22 1/4
WIDTH	10 19/32	10 19/32	10 19/32
LENGTH	49 7/32	59 1/16	74 5/16

8.3.1. Installation dimensions

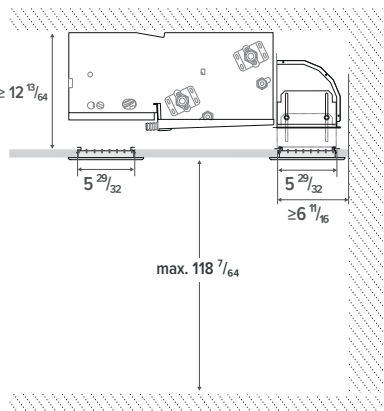
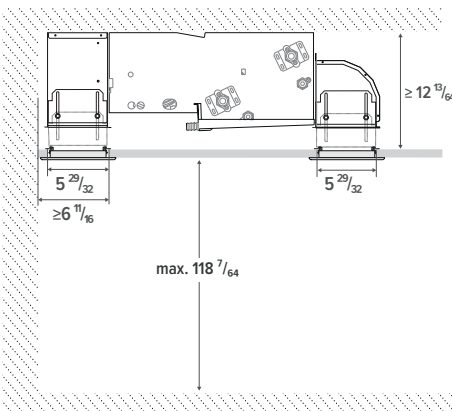

Dimensions in Inches

8.3.2. Hydraulic & electrical connection

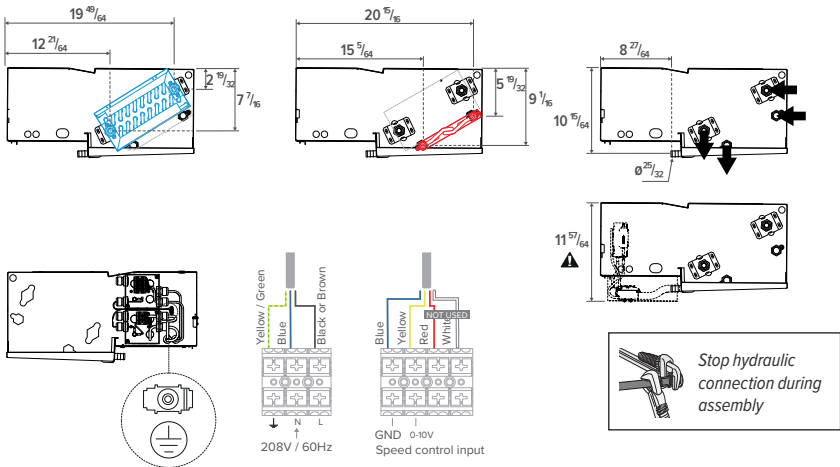

Dimensions in Inches

EN

8.4. INSTALLATION

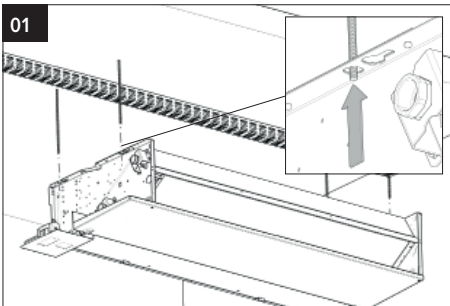

Mark and drill the mounting holes for the device.

- ⚠ The type of wall determines which type of screw or plug must be used.
- ⚠ Make sure that the wall is level and has sufficient loadbearing capacity!

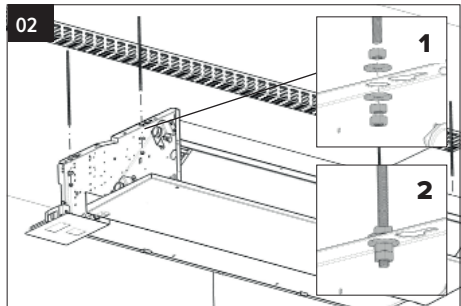

1. Place the screws of the device(5-8) and let them stick out 1 cm. Use a washer between screw head and the appliance. [1]
2. Place the device in the correct position.
3. Tighten the screws. [2]

Threaded rods: mount the unit on the threaded rods. Use a washer between screw head and the appliance.

- ⚠ The installer should provide sound dampening material.

03

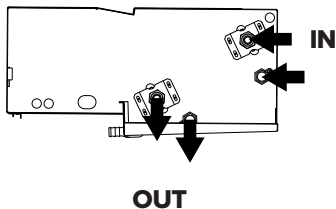

Use a back-off wrench when fastening the hydronic connections!



Remove black plug at hydraulic connection.

Connect the device to the hydraulic system by using the specified inlet/ outlet connections. Make sure that the connections are air tight, use a sealant for this. The coil is equipped with a de-aerater.



If the unit is used for cooling, the hydraulic pipes must be insulated.

When using devices for cooling: iron couplings prohibited.

04

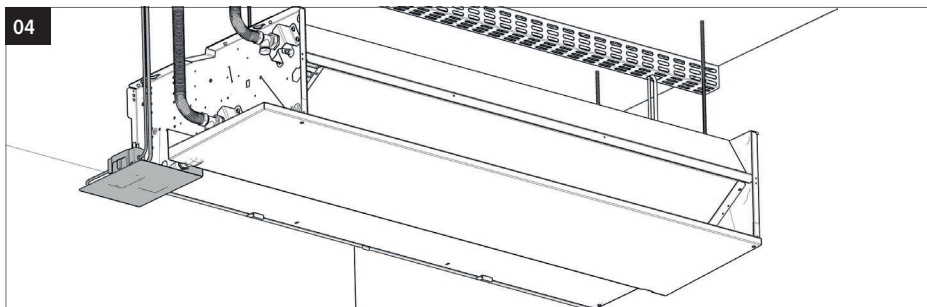

Connect the condensate pump.

05

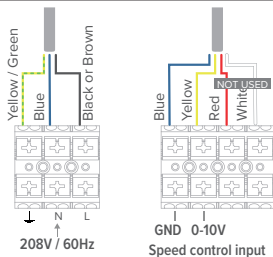
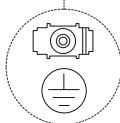
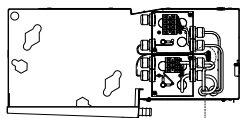

Connect the device electrically.

9. INITIAL START



IMPORTANT!

Start-up and Commissioning of the fancoil must be carried out by skilled staff, qualified to work on this type of product.



DANGER!

Before start-up, make sure the installation has been carried out in compliance with in this manual.

Before start-up the fancoil unit, check if:

1. the unit is positioned correctly
2. the supply and return pipes are properly connected and insulated
3. the pipes are clean and air is removed
4. the inclination of the unit towards the drain and the p-trap are correct
5. the coils are clean
6. the wiring connections are correct and properly tightened
7. the supply voltage is correct
8. the electric power consumption is correct and does not exceed the maximum value indicated in the catalog

10. MAINTENANCE



DANGER!

- maintenance must be carried out by qualified technicians.
 - do not insert sharp objects into the supply and return grilles
- the unit has sharp edges; use gloves during maintenance!



DANGER!

Always use the main disconnect switch to isolate the unit from the mains before carrying out any maintenance or inspection work. Make sure that no one accidentally turns on the power to the unit; lock the master switch in the off position.

10.1. SPECIAL NOTE

Maintenance and cleaning of the stainless steel protection grille:

a dirty grille obstructs the air flow, so clean the grille at regular intervals, depending on the room's purpose and how it's used. The grille should never be disassembled for maintenance and can be easily cleaned by using a vacuum cleaner.

Cleaning the unit:

always disconnect the power supply before servicing the fan!!

- cleaning at regular intervals is important, depending on the room's purpose and how it's used
- clean with a vacuum cleaner or air compressor. Do not use solvent- or detergent based products.

10.2. ROUTINE MAINTENANCE

Every 6 months: Check the condition of the coil and condensate drain:

If necessary:

- remove any dirt from the coil surface
- remove dust using an air compressor
- wash with water and brush gently
- dry by using compressed air
- keep the condensate drain free from any obstructions that may prevent normal water flow

Bleed air from the system.

1. start the circulation pump and open the supply valve for a few minutes.
2. stop the circulation pump.
3. loosen the vent screw on the inlet collector and bleed the air.
4. repeat steps 1 to 3 until there is no more air escaping the system

10.3. ELECTRICAL CIRCUIT

The following steps are recommended to perform maintenance on the electrical circuit:

- check the unit's power consumption using a clip-on meter and compare the reading with the values shown in the documentation;
- inspect the electrical contacts for corrosion and loose wires.

11. WARRANTY

The fan coil unit is intended strictly for conditioning the indoor climate. Any unintended use is strictly forbidden and voids all warranty on the product. Installation, maintenance and operation of the unit is only allowed for authorized staff.

Please follow these instructions carefully

The warranty is void when:

- the installation procedure has not been followed,
- the fan coil has not been periodically cleaned,
- the unit has been used in an improper or irresponsible manner,
- repairs have been carried out by others than Jaga,
- product modifications have been carried out by others, before or after the installation,
- the product is not accessible for cleaning or maintenance.

If you have any questions or complaints, please contact your supplier or installer. The copyright of these instructions is the property of Jaga.

12. DISSASSEMBLY INSTRUCTIONS



SAFEGUARD THE ENVIROMENT

Jaga cares about protecting the environment.

When the unit is dismantled it is important to strictly follow these procedures:

- the unit must be dismantled by a firm that is authorized to dispose of scrap machinery/products

The unit as a whole is composed of secondary raw materials and the following conditions must be met:

- if the unit contains antifreeze, then dispose of the antifreeze as indicated in the glycol supplier's instructions.
- the electronic components are considered special waste, and must be recycled as such
- the pipe insulation and the sound-absorbing lining must be removed and processed as urban waste

Please follow and file these instructions!

13. REFERENCE STANDARDS

UL STD 1995 CSA C22.2 NO. 236	Safety standard for heating and cooling equipment
UNI EN 292	Safety of machinery. Basic concepts, general principles for design
UNI EN 294	Safety of machinery. Safety distances to prevent danger zones being reached by the upper limbs.
UNI EN 563	Safety of machinery. Temperature of contact surfaces. Ergonomic data to establish limit values for temperatures of hot surfaces.
UNI EN 1050	Safety of machinery. Principles of risk assessment.
UNI 10893	Product technical documentation. User instructions
EN 13133	Specifies basic requirements essential to the brazing process, test conditions, assessment and certificates
EN 378-1	Refrigerating systems and heat pumps. Safety and environmental requirements.
PREN 378-2	Refrigerating systems and heat pumps. Design, construction, testing, marking and documentation.
IEC EN 60335-2-40	Particular requirements for electrical heat pumps, air-conditioners and dehumidifiers.
UNI EN ISO 3741 ISO 5135 EUROVENT 8/2-1992	Acoustics. This is the rule used to determine the sound power level measuring the sound pressure level in free field uttered by a noise source nonpunctiform, lied on a surface that reflects acoustically.
EN 50081-1:1992	Electromagnetic compatibility, generic emission standard. Part 1: residential, commercial and light industry.

EN



Jaga Canada Climate Systems
www.jaga-canada.com

27200.20000097
2022.09.27. - Jaga Inc.